

Connections

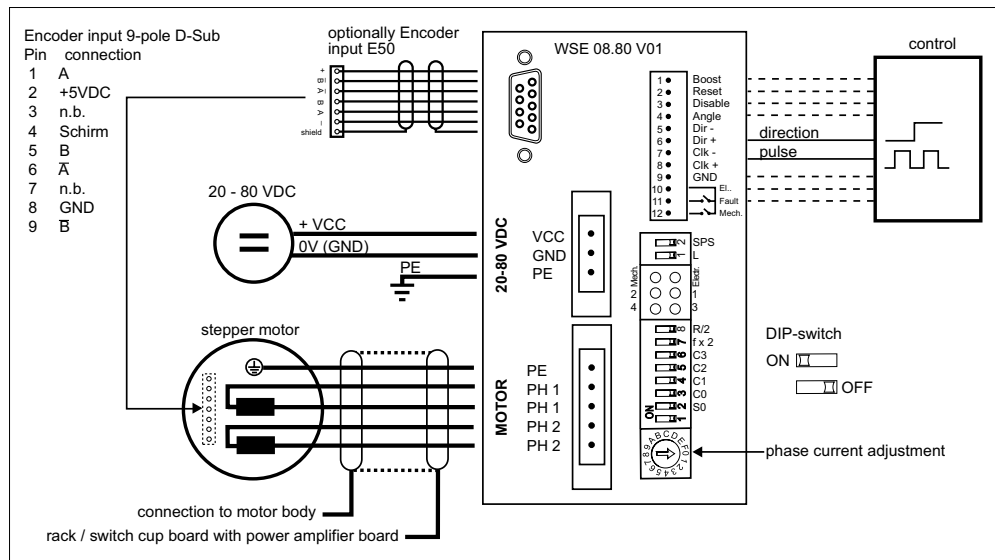

All inputs not used may stay open – it is not necessary to connect them to an external potential.
Pulse and direction are used for a normal stepper motor operation (there is no need to connect the pulse direction signal, if the motor shall run only into one direction).
All other inputs at the signal port may be connected according to the applications requirements.

Technical specifications

protection of device	protection class IP 20, protection against short circuit, over temperature und under voltage
weight	0,5kg or 0,6kg
voltage supply	20 – 80 VDC, ripple max. 5%
ambient conditions	ambient temperature: 0°C to 50°C, max. housing temperature: 85°C
noise imunity	in case of correct installation: according to EN50082-2: – at selected TTL-signal level the inputs are not immune against fast transients (Burst)
noise radiation	In case of correct installation and shielding or/and filtering of the lines and signals according to EN55011 class B
RoHs conform to directive 2002/95/EC	

Available versions: (e.g.: WSE 08.80 V01, WSE 08.80 V01/G, WSE 08.80 V01/W, WSE 08.80 V01/WG, ...)

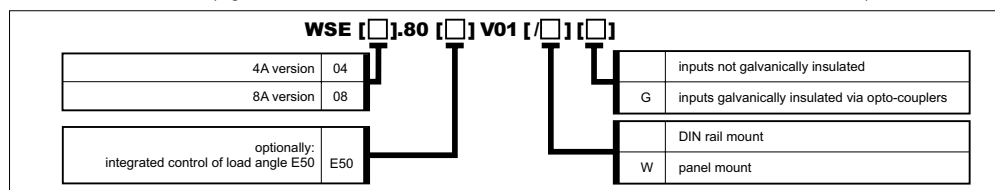

Stepper motor amplifier series WSE 04.80 V01 / 08.80 V01

- Bipolar 2-phases stepper motor control
- Wide range of voltage supply 20 – 80 VDC and phase current adjustable until 4A/Phase or 8A/Phase
- Protected against short circuit (motor phases), over temperature and under voltage
- Selectable step resolutions via DIP switches: 200 – 12800 steps per revolution
- Selectable signal level for inut signals: high-active TTL or high-active SPS (24V) or low-active
- Version WSE... E50 with control of motor load angle (stepper motor with encoder type E50 required)

Dimensions

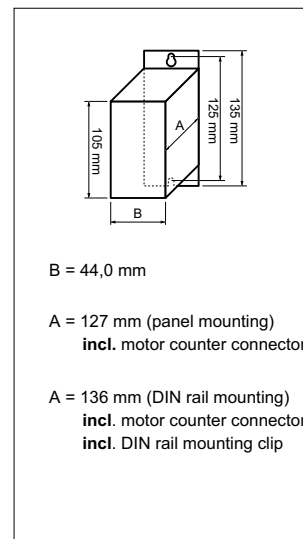

Functional diagram

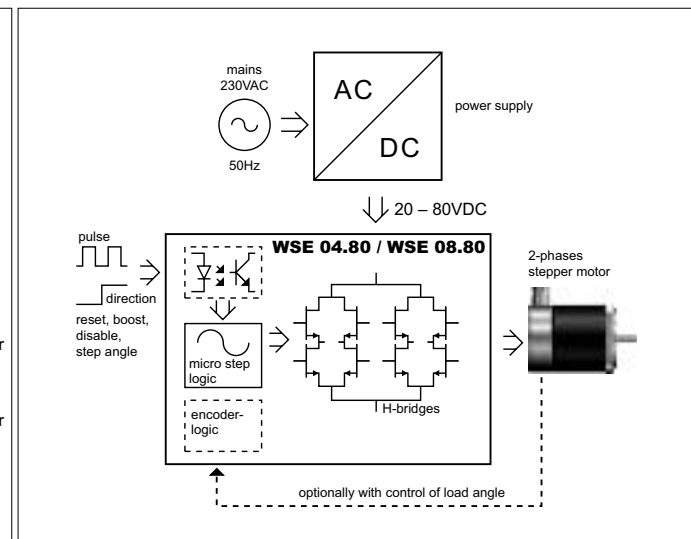

Selections via DIP switches

switch	remarks	factory setting
1	E50 control ON : E50 disabled OFF : E50 enabled	OFF
2 – S0	phase current characteristics ON: SM87/SM88 OFF: SM107	OFF: SM 107
3 – C0	selection step resolution – see step angle table	OFF: 12800 steps / revolution
4 – C1	selection step resolution – see step angle table	OFF: 12800 steps / revolution
5 – C2	selection step resolution – see step angle table	OFF: 12800 steps / revolution
6 – C3	selection step resolution – see step angle table	OFF: 12800 steps / revolution
7 – f x 2	double step – see seperate description	OFF: no double step
8 – R/2	current reduction at stand still ON: I = 100% OFF: I = 50%	OFF: current reduction active
9 – L	signal level input signals – see seperate description	OFF: high active
10 – SPS	signal level input signals – see seperate description	OFF: TTL

Selection of step resolution

Different step resolutions may be selected via the switches 3 to 6 (C0 to C3). Via the input »angle« the step resolution can be switched externally between two values. During motion, switching the step resolution is possible within the motor start-stop-frequency (or at any frequency when changing simultaneously the pulse frequency and step resolution).

steps / revolution resolution externally switchable via the input »Angle«		DIP-switch 3 – 6 for selection of steps / revolution			
input not active	input active	3 (C0)	4 (C1)	5 (C2)	6 (C3)
200	200	ON	ON	ON	ON
400	200	ON	ON	ON	OFF
500	500	ON	ON	OFF	ON
800	400	ON	ON	OFF	OFF
1000	500	ON	OFF	ON	ON
1600	400	ON	OFF	ON	OFF
2000	400	ON	OFF	OFF	ON
2500	500	ON	OFF	OFF	OFF
3200	800	OFF	ON	ON	ON
4000	400	OFF	ON	ON	OFF
5000	500	OFF	ON	OFF	ON
6400	400	OFF	ON	OFF	OFF
8000	500	OFF	OFF	ON	ON
10000	400	OFF	OFF	ON	OFF
10000	1000	OFF	OFF	OFF	ON
12800	800	OFF	OFF	OFF	OFF

If you need other step resolutions, please contact us

Double pulse (switch 7 »f x 2«)

If the switch 7 (f x 2) is ON, then each signal edge at the pulse input will result in the execution of a motor set (rising edges and falling edges will execute motor steps)

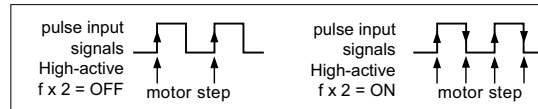

Automatical phase current reduction (switch 8 »R/2«)

If the switch 8 (R/2) is ON, then the phase current at motor standstill will be reduced by 50%. The first coming pulse will rise the phase current again to 100%. If a signal is active at the reset input, then the current reduction will not be activated.

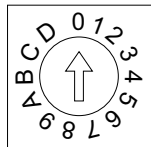

Phase current adjustment

Ex factory the power amplifier is set to 4,2 A. The phase current must be set to the bipolar phase current of the connected stepper motor. The adjustment is done via the rotational switch at the front side of the WSE according to below table. The table value corresponds to the bipolar phase current of the motor.

phase current [A] max. current / type	position of switch															
	0	1	2	3	4	5	6	7	8	9	A	B	C	D	E	F
4 A/Ph.	0,0	0,25	0,55	0,8	1,05	1,35	1,6	1,85	2,15	2,4	2,65	2,95	3,2	3,5	3,75	4,0
8 A/Ph.	0,0	0,5	1,1	1,6	2,1	2,7	3,2	3,7	4,3	4,8	5,3	5,9	6,4	7,0	7,5	8,0

Input- / Output signals description

- Boost:** phase current is increased by 20%
- Disable:** phase current in the motor phases will be shut off
- Reset:** Drive errors are reset, drive in reset position (phase zero), pulse signals are disabled
- Dir:** Control of motor direction
- Clk:** Each pulse executes one motor step
- Angle:** The step resolution will be changed – see step resolution table above
- Ready signal:** An **electrical error** (under voltage, short circuit or over temperature) or a **mechanical error** (only E50 versions) will open the relay contact. Other wise the relay contact is closed (ready for operation)

input signals

signal rise time max.: 1µs, signal fall time max.: 1µs, frequency pulse max.: 200 KHz

input signals HIGH-active

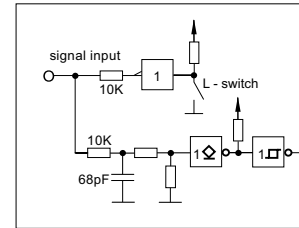

input signals SPS – level

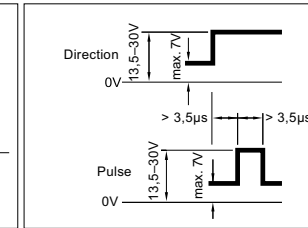

input signals TTL – level

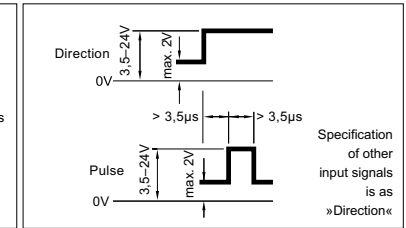

input signals – adjustment signal level – switch 9 (»L«) and 10 (»SPS«)

signal specifications	switch L	switch SPS	connection »Clk« and »Dir« at signal plug port
High-active TTL	OFF	OFF	Clk- and Dir- (Clk+ and Dir+ are not connected)
High-active SPS	OFF	ON	Clk- and Dir- (Clk+ and Dir+ are not connected)
Low-active	ON	OFF	Clk+ and Dir+ (Clk- and Dir- are not connected)
not valid	ON	ON	
RS422	OFF	OFF	Clk+ and Clk- and Dir+ and Dir- (all other signals High-active TTL)
RS422	OFF	ON	Clk+ and Clk- and Dir+ and Dir- (all other signals High-active SPS)

In case of set modes »High-active« and »Low-active« the connection »GND« has to be connected with GND of the control sending the signals »Clk« and »Dir«.

In case of a set mode »RS422« the connection »GND« has to be connected only in case other signals than »CLK« and »Dir« shall be used additionally.

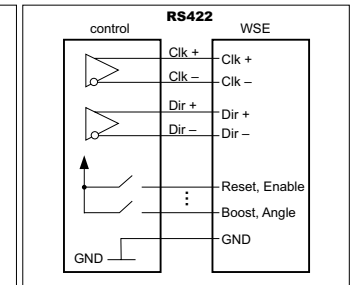
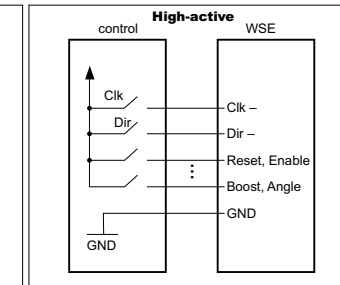
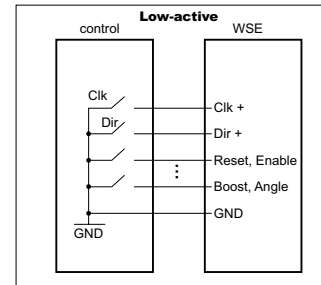

output ready signal

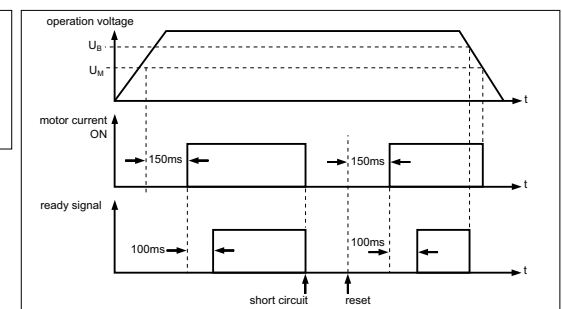
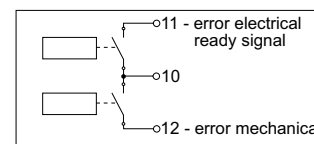

Voltage supply

20 – 80 VDC
max. 5% Rippel

Timing Ready signal, U_B = 14VDC, U_M = 20VDC